

**TYPICAL SECTION NO. 1**  
 S.H. 74D  
 STA. 64+50.00 TO STA. 66+55.58  
 STA. 68+68.42 TO STA. 71+00.00

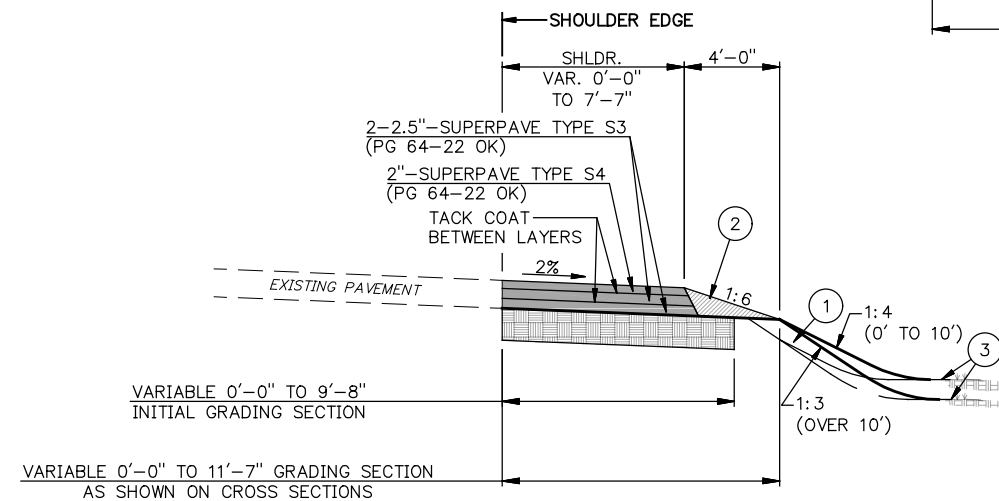

**TYPICAL SECTION NO. 2**  
 S.H. 74D INCIDENTAL CONSTRUCTION  
 STA. 63+88.00 TO STA. 64+50.00

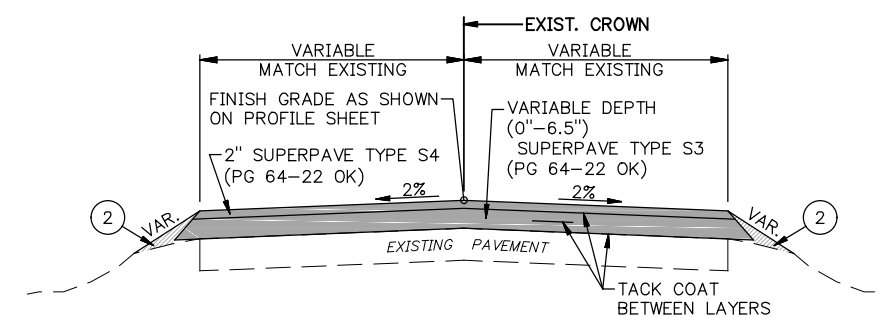

**TYPICAL SECTION NO. 4**  
 EW 69  
 STA. 313+02.00 TO STA. 314+33.28  
 STA. 314+83.36 TO STA. 316+91.00

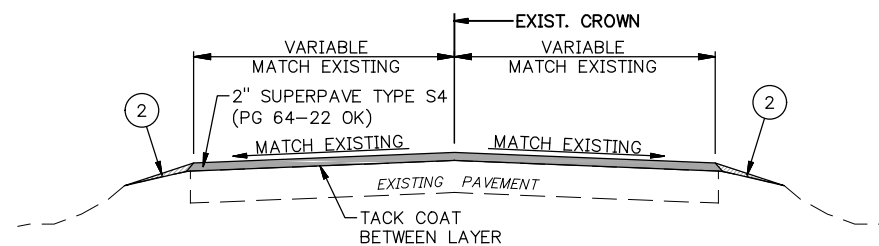

**TYPICAL SECTION NO. 3**  
 EW 69  
 STA. 204+65.00 TO STA. 313+02.00  
 STA. 316+91.00 TO STA. 362+75.00

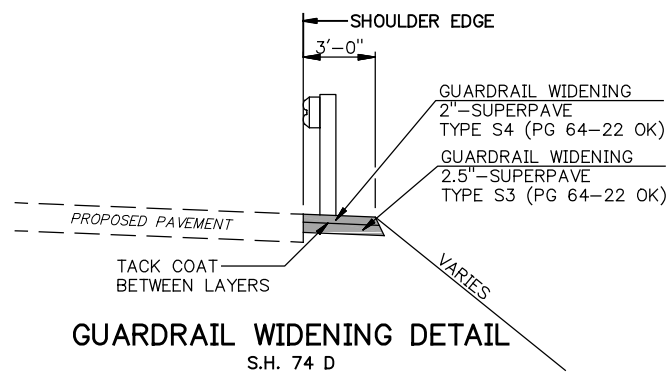

**GUARDRAIL WIDENING DETAIL**  
 S.H. 74 D

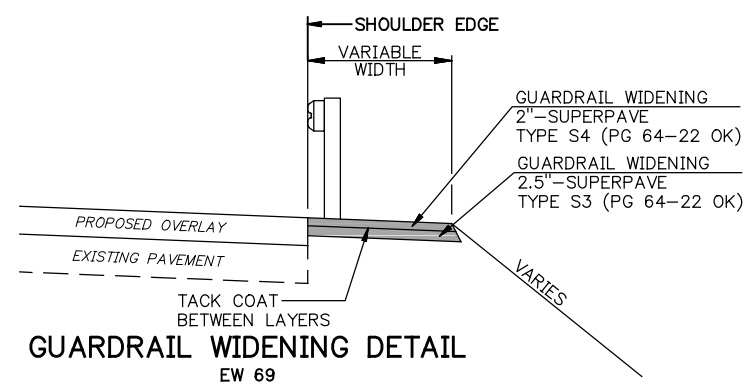

**GUARDRAIL WIDENING DETAIL**  
 EW 69

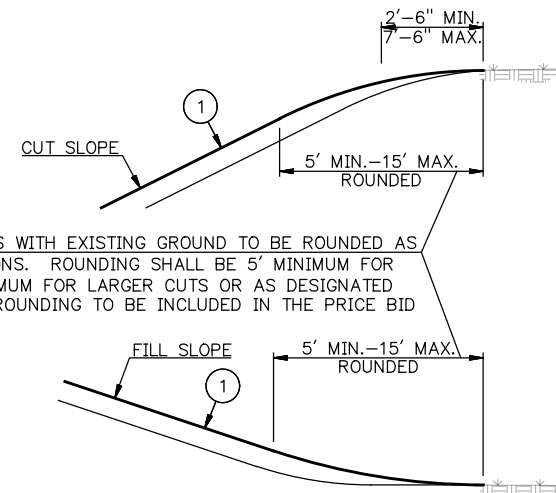

**ROUNDING DETAIL**

INTERSECTION OF CUT SLOPES WITH EXISTING GROUND TO BE ROUNDED AS PART OF FINISHING OPERATIONS. ROUNDED SHALL BE 5' MINIMUM FOR SMALLER CUTS AND 15' MAXIMUM FOR LARGER CUTS OR AS DESIGNATED BY THE ENGINEER. COST OF ROUNDED TO BE INCLUDED IN THE PRICE BID

**TOPSOIL NOTE**  
 (1) THE CONTRACTOR SHALL STRIP ALL OF THE AVAILABLE TOPSOIL, STOCKPILE IT, AND PLACE IT BACK ON THE SECTION IN ACCORDANCE WITH SECTION 205 OF THE STANDARD SPECIFICATIONS. RESERVED TOPSOIL SHALL BE SPREAD FIRST ON THE COMPLETED SLOPES OF THE CUT SECTIONS AND THE REMAINDER ON COMPLETED FILL SLOPES OR OTHER PRIORITY AREAS LOCATED BY THE ENGINEER. ALL ADDITIONAL COSTS ASSOCIATED WITH OPERATIONS SHALL BE INCLUDED IN THE PAY ITEM FOR SALVAGED TOPSOIL, LUMP SUM.  
 THE GRADING LINE AS SHOWN ON THE TYPICAL AND CROSS SECTIONS IS TO THE TOP OF THE TOPSOIL. EARTHWORK QUANTITIES WERE NOT ADJUSTED FOR SALVAGE AND THE TOPSOIL QUANTITY IS INCLUDED IN THE MASSLINE BALANCE.

**BACKFILL NOTE**  
 (2) THIS AREA TO BE BACKFILLED & COMPACTED AS PART OF THE FINISHING OPERATIONS. COST TO BE INCLUDED IN PRICE BID FOR OTHER ITEMS OF WORK.

(3) SEE ROUNDING DETAIL

**TYPICAL SECTIONS**